

RECOMMENDED P.C.B PATTERN LAYOUT

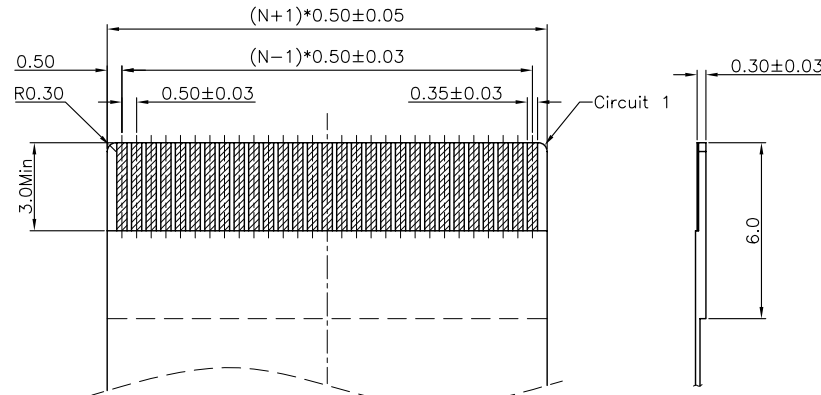
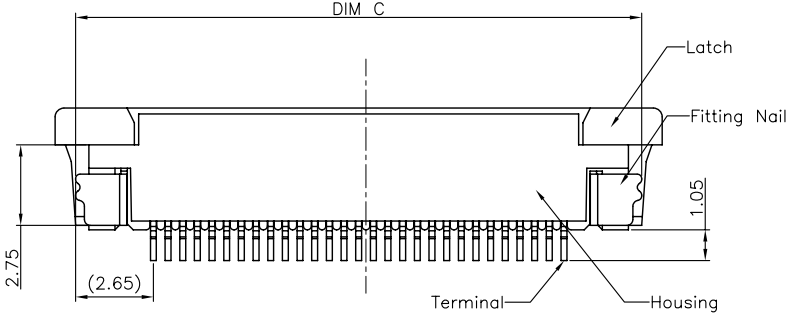
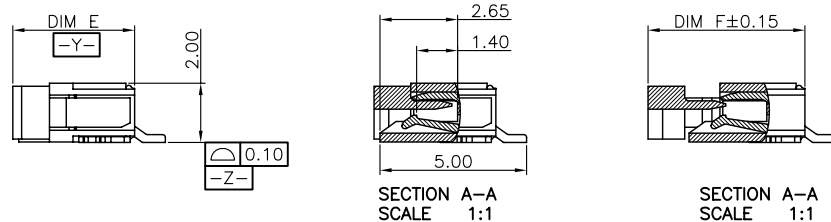
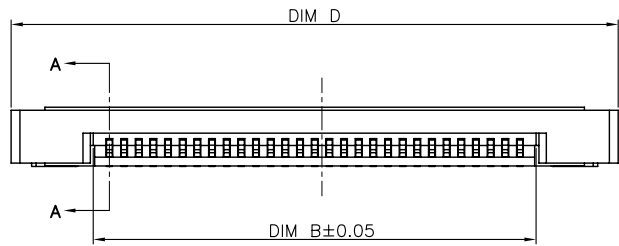

RECOMMENDED FPC/FFC DIMENSION

CKTS	DIM A	DIM B	DIM C	DIM D	DIM E	DIM F
4	1.50	2.60	6.46	7.60		
5	2.00	3.10	6.96	8.10		
6	2.50	3.60	7.46	8.60		
7	3.00	4.10	7.96	9.10		
8	3.50	4.60	8.46	9.60		
9	4.00	5.10	8.96	10.10		
10	4.50	5.60	9.46	10.60		
11	5.00	6.10	9.96	11.10		
12	5.50	6.60	10.46	11.60		
13	6.00	7.10	10.96	12.10		
14	6.50	7.60	11.46	12.60		
15	7.00	8.10	11.96	13.10		
16	7.50	8.60	12.46	13.60		
17	8.00	9.10	12.96	14.10		
18	8.50	9.60	13.46	14.60		
19	9.00	10.10	13.96	15.10	4.15	5.35
20	9.50	10.60	14.46	15.60		
21	10.00	11.10	14.96	16.10		
22	10.50	11.60	15.46	16.60		
23	11.00	12.10	15.96	17.10		
24	11.50	12.60	16.46	17.60		
25	12.00	13.10	16.96	18.10		
26	12.50	13.60	17.46	18.60		
27	13.00	14.10	17.96	19.10		
28	13.50	14.60	18.46	19.60		
29	14.00	15.10	18.96	20.10		
30	14.50	15.60	19.46	20.60		
31	15.00	16.10	19.96	21.10		
32	15.50	16.60	20.46	21.60		
33	16.00	17.10	20.96	22.10		
34	16.50	17.60	21.46	22.60		
35	17.00	18.10	21.96	23.10		
36	17.50	18.60	22.46	23.60		
37	18.00	19.10	22.96	24.10		
38	18.50	19.60	23.46	24.60		
39	19.00	20.10	23.96	25.10		
40	19.50	20.60	24.46	25.60		
41	20.00	21.10	24.96	26.10		
42	20.50	21.60	25.46	26.60		
43	21.00	22.10	25.96	27.10		
44	21.50	22.60	26.46	27.60		
45	22.00	23.10	26.96	28.10		
46	22.50	23.60	27.46	28.60		
47	23.00	24.10	27.96	29.10		
48	23.50	24.60	28.46	29.60		
49	24.00	25.10	28.96	30.10		
50	24.50	25.60	29.46	30.60		
51	25.00	26.10	29.96	31.10		
52	25.50	26.60	30.46	31.60		
53	26.00	27.10	30.96	32.10		
54	26.50	27.60	31.46	32.60		
55	27.00	28.10	31.96	33.10		
56	27.50	28.60	32.46	33.60		
57	28.00	29.10	32.96	34.10		
58	28.50	29.60	33.46	34.60		
59	29.00	30.10	33.96	35.10		
60	29.50	30.60	34.46	35.60	4.70	5.90

- Note:
- Material:
    - Housing: thermoplastic high temp. UL94V-0; Color: natural.
    - Latch: thermoplastic high temp. UL94V-0; Color: black.
    - Terminal: copper alloy T=0.20mm
    - Fitting Nail: copper alloy T=0.20mm
  - Finsh:
    - Terminal: Underplating: matt Tin overall.
    - Fitting Nail: Underplating: matt Tin overall.
  - Product must comply HF RoHS specification.

PART NO. SPEC  
AFC05-SXX X X X-00

NO. OF CKTS  
A: Tape & Reel  
B: Tray package  
C: Tube  
E: Tape & Reel with Mylar  
F: Box with Mylar  
G: Tube with Mylar

CONTACT TYPE  
PLATING CODE  
1: GOLD FLASH 1u"  
2: GOLD FLASH 2u"  
3: GOLD FLASH 3u"  
C: MATT-Tin 90-120u"

PACKING CODE  
A: Tape & Reel  
B: Tray package  
C: Tube  
E: Tape & Reel with Mylar  
F: Box with Mylar  
G: Tube with Mylar

CUSTOMER DRAWING		<b>浙江合丰科技有限公司</b> Zhejiang Hefeng Technology Co.,Ltd	
Tolerance Unspecified (未注公差)	Size (图幅): A4	Product Name (产品名称): 0.5Pitch H=2.0 FPC ZIF CONN. RA SMT Lower TYPE (Half)	
0.0 ±0.15 0° ±5°	Unit (单位): MM	Product No (产品料号): AFC05-S**FCA-00	
0.00 ±0.10 0° 0 ±3°	Scale (比例): 1:1	Designer (设计): Steven 12/23'11	Checked (审核): Allan 12/23'11
0.000 ±0.05 0° 0.00 ±1°	Page (页数): 1 OF 1	Approved (核准):	
Project View (投影视角): 第一角	Rev (版本): A		

Rev 版本	Change Description 变更内容	Date 日期	Revisor 制/修订人
A	初版发行	2011/12/23	Allan