

RECOMMENDED P.C.B PATTERN LAYOUT

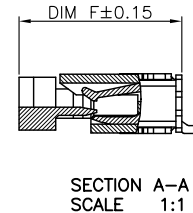

SECTION A-A SCALE 1:1

CKTS	DIM A	DIM B	DIM C	DIM D	DIM E	DIM F
4	1.50	2.60	6.80	8.20		
5	2.00	3.10	7.30	8.70		
6	2.50	3.60	7.80	9.20		
7	3.00	4.10	8.30	9.70		
8	3.50	4.60	8.80	10.20		
9	4.00	5.10	9.30	10.70		
10	4.50	5.60	9.80	11.20		
11	5.00	6.10	10.30	11.70		
12	5.50	6.60	10.80	12.20		
13	6.00	7.10	11.30	12.70		
14	6.50	7.60	11.80	13.20		
15	7.00	8.10	12.30	13.70		
16	7.50	8.60	12.80	14.20		
17	8.00	9.10	13.30	14.70		
18	8.50	9.60	13.80	15.20		
19	9.00	10.10	14.30	15.70	4.35	5.55
20	9.50	10.60	14.80	16.20		
21	10.00	11.10	15.30	16.70		
22	10.50	11.60	15.80	17.20		
23	11.00	12.10	16.30	17.70		
24	11.50	12.60	16.80	18.20		
25	12.00	13.10	17.30	18.70		
26	12.50	13.60	17.80	19.20		
27	13.00	14.10	18.30	19.70		
28	13.50	14.60	18.80	20.20		
29	14.00	15.10	19.30	20.70		
30	14.50	15.60	19.80	21.20		
31	15.00	16.10	20.30	21.70		
32	15.50	16.60	20.80	22.20		
33	16.00	17.10	21.30	22.70		
34	16.50	17.60	21.80	23.20		
35	17.00	18.10	22.30	23.70		
36	17.50	18.60	22.80	24.20		
37	18.00	19.10	23.30	24.70		
38	18.50	19.60	23.80	25.20		
39	19.00	20.10	24.30	25.70		
40	19.50	20.60	24.80	26.20		
41	20.00	21.10	25.30	26.70		
42	20.50	21.60	25.80	27.20		
43	21.00	22.10	26.30	27.70		
44	21.50	22.60	26.80	28.20		
45	22.00	23.10	27.30	28.70		
46	22.50	23.60	27.80	29.20		
47	23.00	24.10	28.30	29.70		
48	23.50	24.60	28.80	30.20		
49	24.00	25.10	29.30	30.70		
50	24.50	25.60	29.80	31.20		
51	25.00	26.10	30.30	31.70		
52	25.50	26.60	30.80	32.20		
53	26.00	27.10	31.30	32.70		
54	26.50	27.60	31.80	33.20		
55	27.00	28.10	32.30	33.70		
56	27.50	28.60	32.80	34.20		
57	28.00	29.10	33.30	34.70		
58	28.50	29.60	33.80	35.20		
59	29.00	30.10	34.30	35.70		
60	29.50	30.60	34.80	36.20		

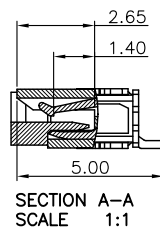
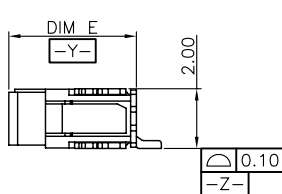
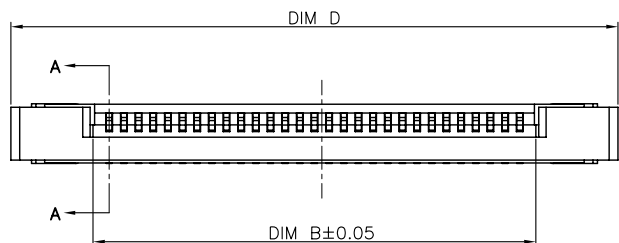
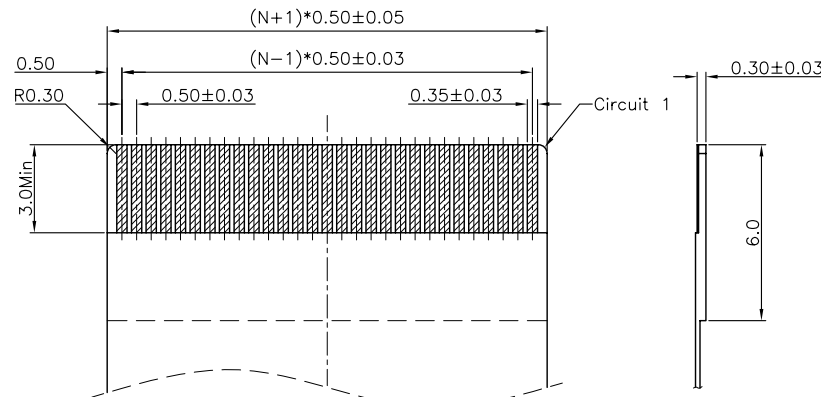
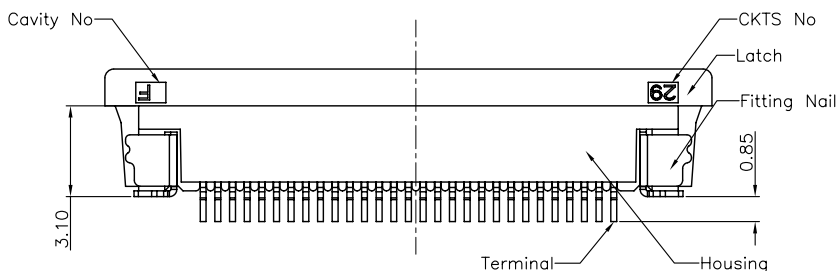

RECOMMENDED FPC/FFC DIMENSION

- Note:
- Material:
 - Housing: thermoplastic high temp. UL94V-0; Color: natural.
 - Latch: thermoplastic high temp. UL94V-0; Color: black.
 - Terminal: copper alloy T=0.20mm
 - Fitting Nail: copper alloy T=0.20mm
 - Finsh:
 - Terminal: Underplating: matt Tin overall.
 - Fitting Nail: Underplating: matt Tin overall.
 - Product must comply HF RoHS specification.

PART NO. SPEC
AFC06-SXX X X X-HF

NO. OF CKTS
CONTACT TYPE
PLATING CODE

PACKING CODE
A:Tape & Reel
B:Tray package
C:Tube
E:Tape & Reel with Mylar
F:Box with Mylar
G:Tube with Mylar

1:GOLD FLASH 1u"
2:GOLD FLASH 2u"
3:GOLD FLASH 3u"
C:MATT-Tin 90-120u"

CUSTOMER DRAWING

Tolerance Unspecified (未注公差)	Size (图幅): A4
0.0 ±0.15 0° ±5°	Unit (单位): MM
0.00 ±0.10 0° 0° ±3°	Scale (比例): 1:1
0.000 ±0.05 0° 0° 0° ±1°	Page (页数): 1 OF 1
Project View (投影视角)	Rev (版本): A



浙江合丰科技有限公司
Zhejiang Hefeng Technology Co.,Ltd

Product Name (产品名称): 0.5Pitch H=2.0 FPC ZIF CONN. R/A SMT Upper TYPE(2)

Product No (产品料号): AFC06-S**ECA-HF

Designer (设计): Steven 12/23'11

Checked (审核): Allan 12/23'11

Approved (核准):

A	初版发行	2011/12/23	Allan
Rev 版本	Change Description 变更内容	Date 日期	Revisor 制/修订人