

- Note:**
- Material:**
 - Housing: thermoplastic high temp.UL94V-0; Color: natural.
 - Latch: thermoplastic high temp.UL94V-0; Color: black.
 - Terminal: copper alloy T=0.15mm
 - Fitting Nail: copper alloy T=0.20mm
 - Finsh:**
 - Terminal:**
Underplating: matt Tin overall.
 - Fitting Nail:**
Underplating: matt Tin overall.
 - Product must comply HF RoHS specification.**

PART NO. SPEC
 AFC04-SXX X X X-HF

NO. OF CKTS | **PACKING CODE**
 A:Tape & Reel
 B:Tray package
 C:Tube
 E:Tape & Reel with Mylar
 F:Box with Mylar
 G:Tube with Mylar

CONTACT TYPE

PLATING CODE
 1:GOLD FLASH 1u"
 2:GOLD FLASH 2u"
 3:GOLD FLASH 3u"
 C:MATT-Tin 90-120u"

Halogen Free

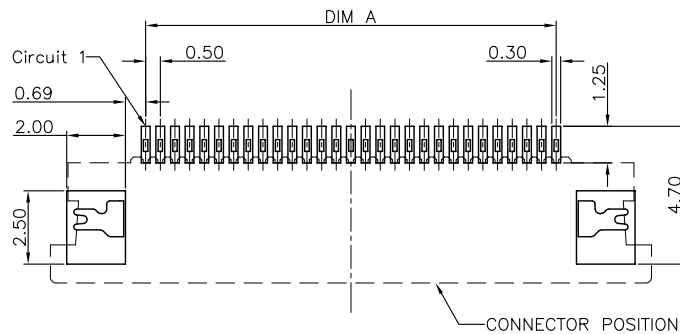

RECOMMENDED P.C.B PATTERN LAYOUT

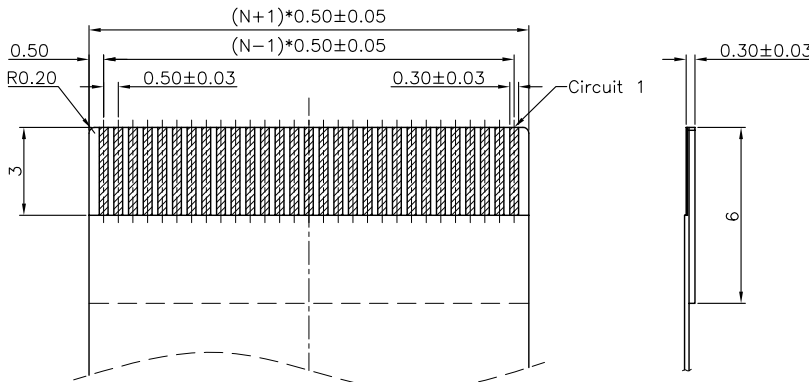
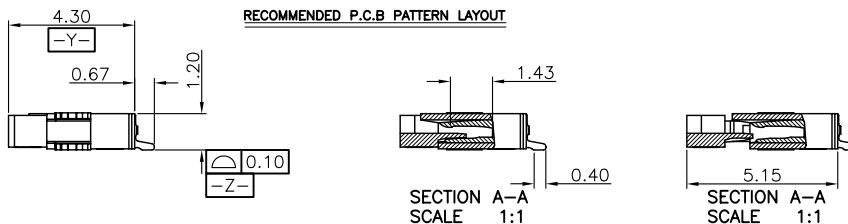

RECOMMENDED FPC/FFC DIMENSION

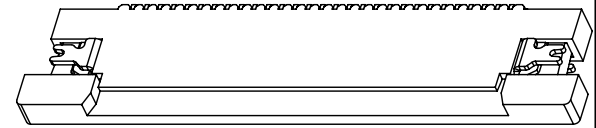

CKTS	DIM A	DIM B	DIM C	DIM D
4	1.50	2.60	6.80	8.00
5	2.00	3.10	7.30	8.50
6	2.50	3.60	7.80	9.00
7	3.00	4.10	8.30	9.50
8	3.50	4.60	8.80	10.00
9	4.00	5.10	9.30	10.50
10	4.50	5.60	9.80	11.00
11	5.00	6.10	10.30	11.50
12	5.50	6.60	10.80	12.00
13	6.00	7.10	11.30	12.50
14	6.50	7.60	11.80	13.00
15	7.00	8.10	12.30	13.50
16	7.50	8.60	12.80	14.00
17	8.00	9.10	13.30	14.50
18	8.50	9.60	13.80	15.00
19	9.00	10.10	14.30	15.50
20	9.50	10.60	14.80	16.00
21	10.00	11.10	15.30	16.50
22	10.50	11.60	15.80	17.00
23	11.00	12.10	16.30	17.50
24	11.50	12.60	16.80	18.00
25	12.00	13.10	17.30	18.50
26	12.50	13.60	17.80	19.00
27	13.00	14.10	18.30	19.50
28	13.50	14.60	18.80	20.00
29	14.00	15.10	19.30	20.50
30	14.50	15.60	19.80	21.00
31	15.00	16.10	20.30	21.50
32	15.50	16.60	20.80	22.00
33	16.00	17.10	21.30	22.50
34	16.50	17.60	21.80	23.00
35	17.00	18.10	22.30	23.50
36	17.50	18.60	22.80	24.00
37	18.00	19.10	23.30	24.50
38	18.50	19.60	23.80	25.00
39	19.00	20.10	24.30	25.50
40	19.50	20.60	24.80	26.00
41	20.00	21.10	25.30	26.50
42	20.50	21.60	25.80	27.00
43	21.00	22.10	26.30	27.50
44	21.50	22.60	26.80	28.00
45	22.00	23.10	27.30	28.50
46	22.50	23.60	27.80	29.00
47	23.00	24.10	28.30	29.50
48	23.50	24.60	28.80	30.00
49	24.00	25.10	29.30	30.50
50	24.50	25.60	29.80	31.00
51	25.00	26.10	30.30	31.50
52	25.50	26.60	30.80	32.00
53	26.00	27.10	31.30	32.50
54	26.50	27.60	31.80	33.00
55	27.00	28.10	32.30	33.50
56	27.50	28.60	32.80	34.00
57	28.00	29.10	33.30	34.50
58	28.50	29.60	33.80	35.00
59	29.00	30.10	34.30	35.50
60	29.50	30.60	34.80	36.00

CUSTOMER DRAWING

Tolerance Unspecified (未注公差): 0.0 ±0.15 0° ±5°
 0.00 ±0.10 0° ±3°
 0.000 ±0.05 0° 0' ±1°

Size (图幅): A4
 Unit (单位): MM
 Scale (比例): 1:1

Project View (投影视角): 1 OF 1

Rev (版本): A

浙江合丰科技有限公司
 Zhejiang Hefeng Technology Co.,Ltd

Product Name (产品名称): 0.5Pitch H=1.2 FPC ZIF CONN. R/A SMT Upper TYPE
 Product No (产品料号): AFC04-S**ECA-HF

Designer (设计): Steven 12/23'11
 Checked (审核): Allan 12/23'11
 Approved (核准):

Rev 版本	Change Description 变更内容	Date 日期	Revisor 制/修订人
A	初版发行	2011/12/23	Allan